

tepeo

ZEB[®] - Zero Emission Boiler

Installation Manual



ZEB-40R

Keep these instructions in a safe place for future reference



Document Purpose

To instruct *competent* persons how to safely install a ZEB®. *Competent* persons are those suitably qualified to carry out plumbing and electrical work and have successfully completed product training by tepeo or an authorised training partner.

Contents

1. General Information	4
1.1. Installation and Operating Instructions	4
1.2. Symbols and Hazard Statements	4
1.3. User Competence, Qualification, and Approval	4
1.4. Compliance with Safety Laws and Regulations	5
1.5. Service and Support	6
2. Safety Instructions	7
2.1. Intended Use	7
2.2. Clearance Requirements	7
2.3. Mechanical Safety	7
2.4. Electrical Safety	8
2.5. Water Safety	9
2.6. Post-Installation Safety	9
2.7. Servicing and Maintenance	10
3. ZEB® Product Details	11
3.1. Introduction	11
3.2. Product Details	11
3.3. Technical Specifications	12
3.4. Product Drawings	13
4. Pre-Installation	16
4.1. Electrical Supply	16
4.2. Communications Box	16
4.3. Water System	17
4.4. Location and Space Requirements	19
5. Installation	22
5.1. Preparation	22
5.2. Electrical and Wiring Installation	23
5.3. Communications Box Wiring	24
5.4. Plumbing Installation	26
6. Commissioning	27
6.1. Installer Application	27
6.2. Commissioning Process	28
6.3. End User Handover	30

7. Operation	31
7.1. Switch On/Off	31
7.2. Comms Box Buttons, LED Indicators and Status	31
7.3. User App	32
8. Maintenance	35
8.1. Support - Care Plans	35
8.2. Front panel removal	35
8.3. Cleaning	36
9. Recycling and Disposal	37
10. Appendices	38
10.1. Example Comms Box Wiring Diagrams	38
11. Notes	39





1. General Information

1.1. Installation and Operating Instructions

The ZEB® must be installed in accordance with these instructions (which we reserve the right to amend or append from time to time) and in accordance with current regulations in force. Please read these instructions carefully before installing or using the appliance.

1.2. Symbols and Hazard Statements

A triangle symbol is used to indicate a hazard; a circle symbol indicates a point of information. Hazards are divided into three categories of severity - CAUTION, WARNING and DANGER. The table below gives a generic explanation. Specific hazards are detailed in the manual at the appropriate juncture.

Symbol	Hazard and Explanation
 DANGER	DANGER Indicates a hazard with a high level of risk, that if not avoided, will result in death or serious injury
 WARNING	WARNING Indicates a hazard with a medium level of risk, that if not avoided, could result in death or serious injury
 CAUTION	CAUTION Indicates a hazard with a low level of risk, that if not avoided, could result in minor or moderate injury
	TAKE NOTICE Important information regarding the usage or installation of the appliance

1.3. User Competence, Qualification, and Approval

- ONLY competent persons who are suitably qualified to carry out plumbing and electrical work and have successfully completed product training by tepeo or an authorised training partner may undertake installations, repairs or relocations.
- DO NOT allow children or any other unqualified or unapproved persons to install, repair, clean, relocate, interfere or tamper with the product.
- This product is not designed for use by children, or persons with reduced physical, sensory or mental capabilities, and should not be used by such persons unless they can do so safely. Where necessary, such persons (or anyone with lack of experience or knowledge) should first be given supervision or instruction concerning use of the product by a person responsible for their safety.
- tepeo accepts no responsibility of unsatisfactory performance of the ZEB® that is the result of failure to comply with the user instructions.
- tepeo is not responsible for the selection or specification of the equipment required to install the ZEB (heating system or electrical components), unless stated in writing. Responsibility lies with the customers and any experts or consultants involved in design or installation.
- If the ZEB® is to be re-installed in an alternative location or re-sold it must be re-registered with tepeo. Unless otherwise confirmed in writing, reinstallation will not extend or reset our guarantee.

1.4. Compliance with Safety Laws and Regulations

- The ZEB® meets the standards and regulations applicable under UKCA marking:
 - Household and similar electrical appliances - Safety EN60335
 - Electromagnetic Compatibility Regulations 2016
 - Electrical Equipment (Safety) Regulations 2016
 - Radio Equipment Regulations 2017
 - Ecodesign of Energy-Related Products - Retained Commission Regulation (EU) 813/2013
 - The Restriction of the Use of Certain Hazardous Substances in Electrical and Electronic Equipment Regulations 2012
- The ZEB® meets the standards and regulations applicable under CE marking:
 - Household and similar electrical appliances - Safety EN60335

- Electromagnetic Compatibility - Directive 2014/30/EU
 - Low Voltage Directive 2014/35/EU
 - Radio Equipment - Directive 2014/53/EU
 - Ecodesign of Energy-Related Products - Directive 2009/125/EC
 - The Restriction of the Use of Certain Hazardous Substances in Electrical and Electronic Equipment Regulations 2012
- tepeo declares that the materials used in the manufacturing of this appliance are non-hazardous and that no substances harmful to health are contained within the appliance (according to EC No.1272/2008).
 - Installations, repairs and relocations must comply with all relevant local laws and regulations ('statutory obligations'), particularly concerning electrics, water supplies, building regulations and Manual Handling Operations, as issued by the Government Health and Safety Executive ('HSE'). Water distribution and central heating installations ('systems') must comply with all statutory obligations.
 - Statutory obligations always override manufacturer documentation where there is a conflict.
 - Where applicable, this manual should be read in conjunction with manufacturer documentation for any components specified in the installer requirements of this manual.

1.5. Service and Support

For safety information and technical support please contact:

tepeo Ltd

630 Wharfedale Road

Winnersh Triangle

Wokingham

RG41 5TP

customer.service@tepeo.com

tepeo.com

Read the full Safety Instructions in [Section 2](#) of this manual before you install this product

2. Safety Instructions

tepeo Ltd is not responsible for the failure of components not specified in the manual and/or supplied by other manufacturers.

2.1. Intended Use

The intended use of the ZEB[®] is to provide heat to a wet central heating system. The ZEB[®] is a dry core storage boiler incorporating electric heating elements and a smart charging algorithm. It uses live data via the internet to optimise for the lowest cost of heating and the greenest electricity based on user-set tariff & preferences.

The regular ZEB[®] can provide heating of potable water via a separate indirect water cylinder (not supplied) or heat battery/thermal store.

Only use this product for the intended purpose described in this manual.

2.2. Clearance Requirements

 CAUTION	<p>Hot Surface Minor or moderate personal injury - Outer panels may get hot during normal operation</p>
---	--

- Clearance requirements are critical to safe operation of the ZEB[®]. The clearances outlined in this manual must be adhered to and maintained for safe installation of the ZEB[®].
- If installed in an enclosed space, ventilation must be provided.
- Combustible materials must under no circumstances be placed against or on top of the ZEB[®] or any of its ancillaries.

2.3. Mechanical Safety

 CAUTION	<p>Crushing of Feet Minor or moderate personal injury - Wear suitable PPE when handling the product</p>
---	--

The ZEB® requires suitable lifting equipment and handling. The unit is heavy - do NOT try and lift the unit or move the unit without the suitable moving and lifting equipment. Failure to do so may result in personal injury or/and damage to the product.

tepeo is not responsible for damage to property, personal injury and damage to the product that has arisen from incorrect handling.

- DO NOT install the ZEB outdoors. This product is only suitable for indoor installations.
- DO NOT tilt the product more than 30 degrees during the transportation or installation process.
- The ZEB® should be moved into position using appropriate lifting and mechanical handling equipment, and should NOT be moved in a way that knocks or jolts it.
- Install the product on a hard, solid, flat and level surface that can support its weight.
- Care MUST be taken during all hot works (such as soldering or brazing) to protect the paint and panels on the ZEB®
- DO NOT immerse this product in water or any other liquid.
- Care should be taken not to cause damage when moving the ZEB.

2.4. Electrical Safety

 DANGER	<p>Electric Shock Death or serious personal injury</p> <ul style="list-style-type: none"> - Switch off the power supply before starting any work - Isolate the ZEB at the local double pole switch and at the consumer unit - Follow safe isolation procedures - Use voltage indicator and proving unit to verify isolation
--	---

- The product must be earthed correctly and have its own independent electrical supply (with correct voltage and circuit breakers).
- The mains isolator should be readily identifiable, accessible, visible and adjacent to the ZEB® installation.

- Connection must allow double-pole isolation of the electrical supply. The means of isolation must be accessible to the end user after installation.
- The dedicated electrical supply to the ZEB® must be protected by a Residual Current Device (Type A).

2.5. Water Safety

 CAUTION	<p>Pressurised System</p> <p>Minor or moderate personal injury</p> <p>- Before dismantling pipework, close isolating valve on the flow and return to the ZEB® and drain the system. The water may be hot and under pressure.</p>
---	---

- **Maximum** working pressure of the ZEB® must not exceed **0.6MPa (6 bar)**.
- The ZEB does not have an integrated pressure relief valve. Therefore a pressure relief valve **MUST** be fitted within the connected primary water system, set to relieve at or below **0.6MPa (6 bar)** unless on a vented system.

2.6. Post-Installation Safety

- All goods are sold subject to tepeo's 'Terms & Conditions of Sale', as listed on our website at www.tepo.com/terms
- As tepeo continuously improves products, they may be modified without notice. Updated documentation will be produced, supplied with new product ranges and made available on request. It is the responsibility of the installer to ensure they are using the correct instructions for the product being installed.
- Once installed:
 - Perform all test procedures as detailed in the [Commissioning](#) section
 - Explain all safety precautions to the end user
 - Provide a copy of this manual to the end user
- It is the responsibility of the end user to supply this manual to any other subsequent users.

2.7. Servicing and Maintenance

 CAUTION	Hot Surface Minor or moderate personal injury - Some components get hot during normal operation. Allow to cool and wear suitable PPE
---	--

 CAUTION	Safe Handling of Materials Minor or moderate personal injury - Some insulating materials within the ZEB® are delicate and fibrous. NB this product contains bio-soluble Alkaline-Earth Silicate (AES) wools - Care should be taken when handling insulation to minimise dust emissions - Suitable PPE, including an appropriate (e.g. FFP2) respirator, must be worn
---	---

- DO NOT attempt to carry out repairs or maintenance before the core is below 10% State of Charge and other system components have cooled down to ambient room temperature. To speed up the process, disable charging in the user app (e.g. by turning on Away Mode) and set the house thermostat to call for heat. This will reduce the core temperature as the ZEB discharges.
- If the ZEB® is to be re-installed in an alternative location or re-sold it must be re-registered with tepeo.
- There are no user serviceable, adjustable, or settable parts in this product.

**SAVE THESE INSTRUCTIONS AND
PROVIDE A COPY TO THE END USER**

3. ZEB[®] Product Details

3.1. Introduction

The ZEB[®] (Zero Emission Boiler) is an electrically heated dry core storage boiler. The smart charging algorithm uses grid electricity to heat a solid storage medium. It can then deliver this stored energy on demand to heat a central heating and indirect hot water system.

The ZEB[®] is:

- Designed to heat a wet central heating system to a maximum flow temperature of 80°C
- A suitable replacement for gas and oil boilers without the need for larger radiators or extensive plumbing rework - depending on the heating system design and heat load of the home
- Suitable for hot water systems using an indirect cylinder as part of an S, Y, or W-plan system
- Internet-enabled to optimise charging for the lowest cost of heating and greenest electricity
- Compatible with time-of-use tariffs and PV self-generation
- A class I stationary appliance using mains voltage electricity

For more information please visit our website at www.tepeo.com

3.2. Product Details

The ZEB-40R is a 40kWh storage capacity unit designed to replace a heat only/regular boiler. The unit has no internal circulating pump, as it is intended to supply power to an external pump.

When installing as part of a sealed system the unit will require an external pressure relief valve and expansion vessel appropriately sized for the water circuit.

3.3. Technical Specifications

ZEB-40R : Technical Specifications			
Type Designation	Unit	Value	See Notes
Central Heating (CH)			
Rated Heat Output	kW	1 - 15	1
Design Water Pressure	MPa / Bar	1.0 / (10)	
Max. CH Working Pressure	MPa / Bar	0.6 / (6)	
Min. CH Working Pressure	MPa / Bar	0.025 / (0.25)	
CH Flow Temperature Setpoint	°C	35 - 80	2
Min. Flow rate	l/min (l/hr)	3.5 (210)	
Max. Flow rate	l/min (l/hr)	40 (2400)	
Electrical Data			
Electrical Supply Voltage (AC)	V	230V +10%, -6%	
Electrical Frequency	Hz	50	
Rated Current Draw (@230V)	A	41.5	
Boiler Dimensions and Weight			
Height	mm	980	
Width	mm	598	
Depth	mm	660	
Weight	kg	375	
IP Rating		IPX1	
CH Flow/Return pipe diameters	mm	22	
Heat Storage and Temperature Data			
Heat Storage Capacity	kWh	40	
Max temperature rise on panels	°C	60	3
Max ambient temperature - operation	°C	40	
Max ambient temperature - storage	°C	55	
Min ambient temperature	°C	5	
Standard Clearances - See installation section for details			
Above Casing	mm	75	
Sides	mm	50	
Rear of unit	mm	50	
Front (during operation)	mm	50	
Front (withdrawal space for servicing)	mm	500	

Notes

1. Rated power output may be reduced at low State of Charge
2. Flow temperature may be reduced at low State of Charge
3. Max temperature rise is the temperature of the outer panels above the ambient temperature (EN60335)

3.4. Product Drawings

User Interfaces

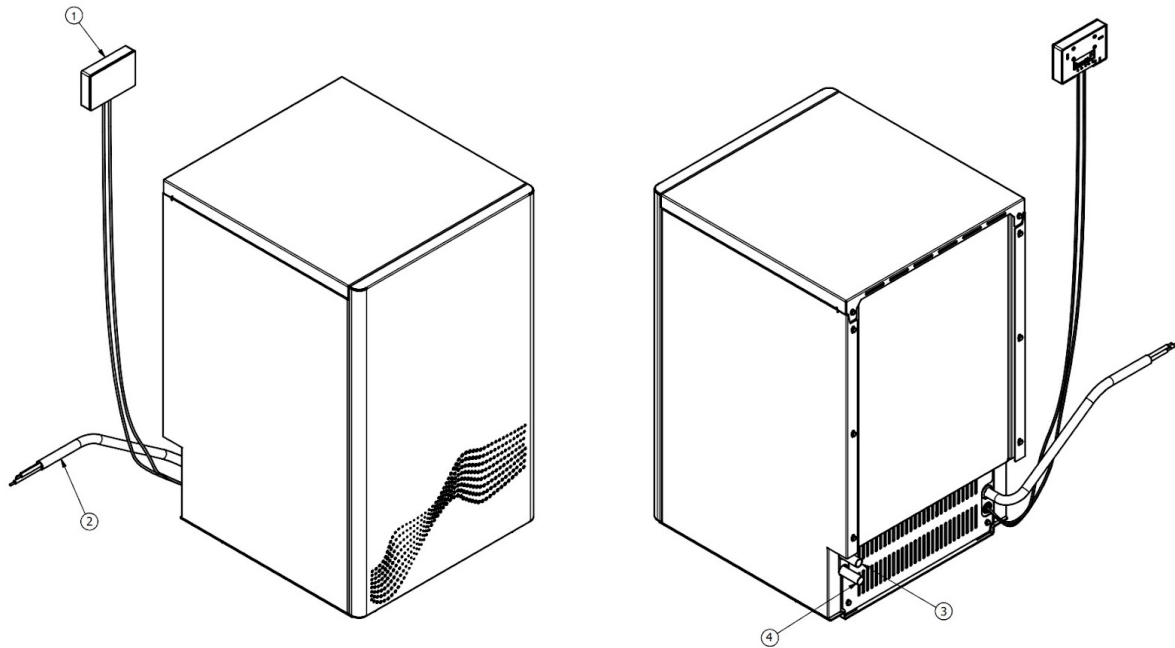

Figure 1: ZEB® User interfaces

Note	Description
1	Communication box (on 2m tether to ZEB®)
2	Mains power cable (supplied as 2m flying lead)
3	Central heating - Flow
4	Central heating - Return

System Layout

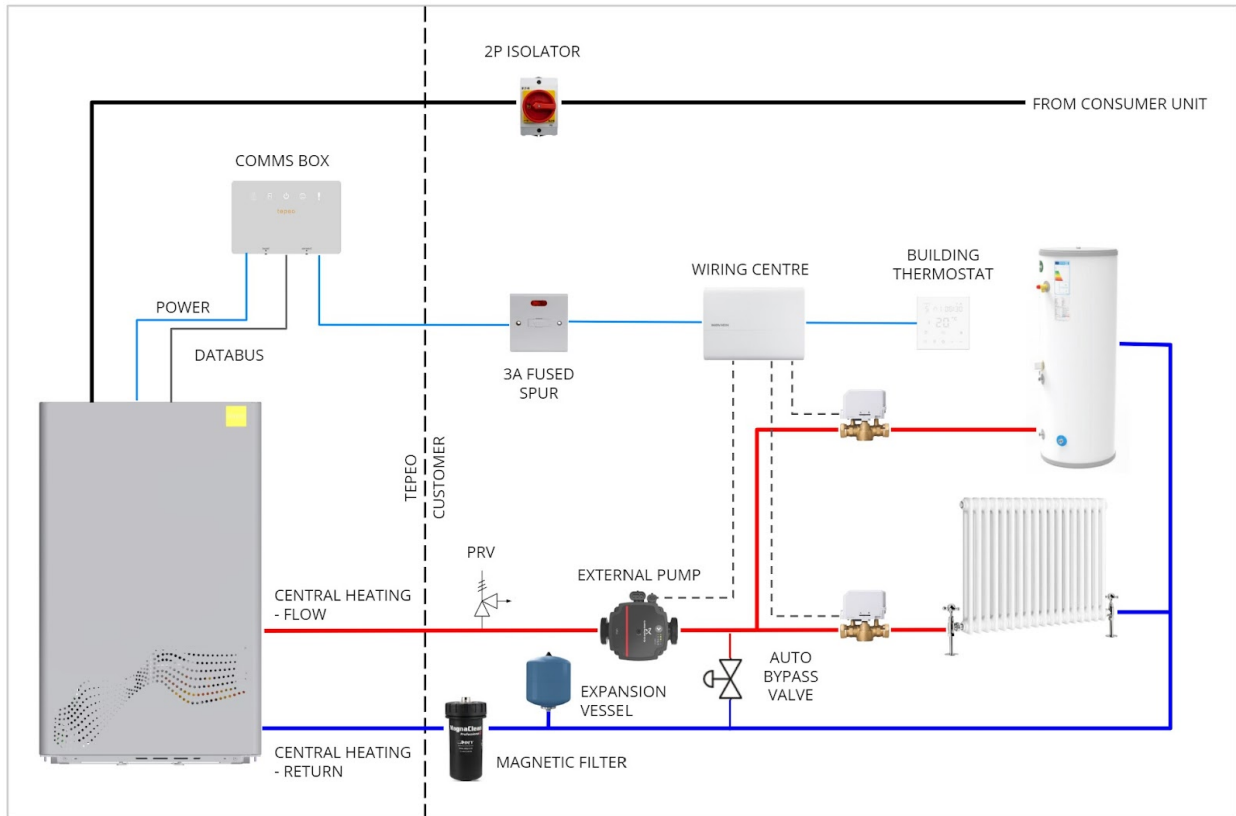



Figure 2: Typical ZEB® System Layout

Mains Voltage Cable Schematic

 DANGER	<p>Electric Shock Death or serious personal injury</p> <ul style="list-style-type: none"> - Switch off the power supply before starting any work - Isolate the ZEB at the local double pole switch and at the consumer unit - Follow safe isolation procedures - Use voltage indicator and proving unit to verify isolation
--	---

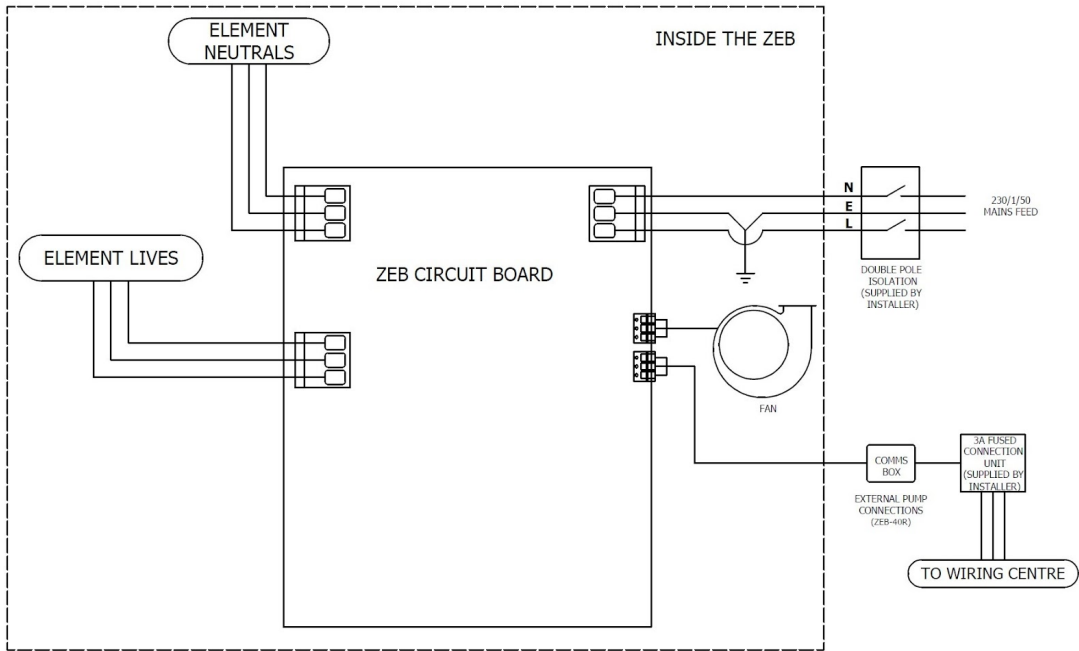

Figure 3: ZEB® mains voltage wiring schematic

Internal Plumbing Schematic

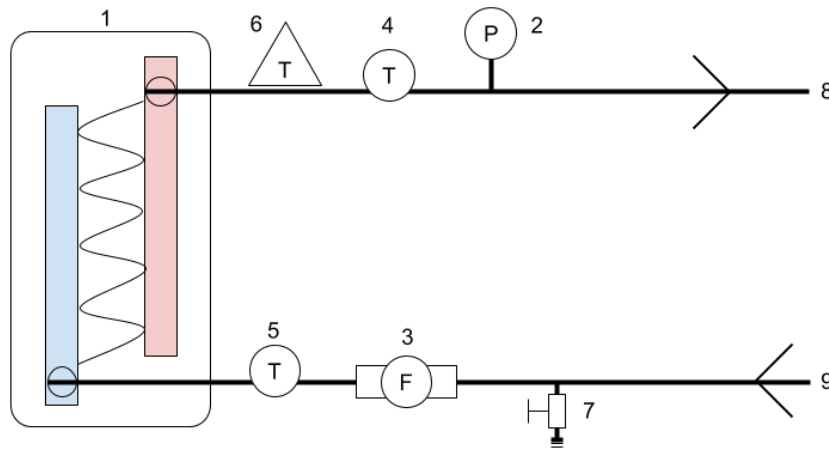



Figure 4: ZEB® internal plumbing schematic

Item	Description	Item	Description
1	Heat exchanger	6	Over-temperature cutoff
2	Pressure Sensor	7	Drain point
3	Flow sensor	8	Flow connection
4	Flow temperature sensor	9	Return connection
5	Return temperature sensor		

4. Pre-Installation

The following sections outline the necessary steps to take in preparation for installing a ZEB®. ONLY competent persons who are suitably qualified to carry out plumbing and electrical work and have successfully completed product training by tepeo or an authorised training partner may undertake installations.

4.1. Electrical Supply

	<p>TAKE NOTICE</p> <p>The use of voltage limiting devices, voltage optimisers and other equipment that interfere with the electrical supply to the property may adversely affect the performance of the ZEB®</p>
---	---

The ZEB requires a dedicated electrical supply from the distribution board. All wiring from the distribution board up to and including the local isolation switch must be completed by a qualified electrician and in accordance with the applicable electrical wiring installation regulations (e.g. BS7671 Requirements for Electrical Installations)

- Install a dedicated 50 Amp type B MCB at the distribution board
- Install RCD protection (30mA type A) at the distribution board
- Install a double pole isolation switch local to the ZEB® and ideally within 2m - it must be accessible without reaching over the unit
- Ensure there is a suitable earth connection available
- Ensure the main fuse & distribution board supplying the property has sufficient capacity for the ZEB®, allowing for diversity requirements

The ZEB® is designed to supply power to an existing wiring centre, from the communications (“comms”) box (see figure 8). Any load supplied with power from the comms box requires fused protection, therefore it is also necessary to:

- Install a 3A unswitched fused spur in line with the power supply from the ZEB® comms box (i.e. between the comms box and an existing wiring centre)

4.2. Communications Box

The communication box is responsible for WiFi connection to the ZEB® and connection to the building thermostat call-for-heat, as well as providing a power supply for the building wiring centre and/or an external pump.

The ZEB® requires connection to the internet to optimise charging for the lowest cost of heating and greenest electricity. The ZEB® can however tolerate temporary interruptions to internet connectivity, but optimal charging based on live sources of data (weather, grid carbon intensity etc) will be compromised. If offline, the ZEB will repeat the charging profile from the previous day.

The communication box is on a 2m flying lead and is intended to be wall mounted.

- Prepare a mounting site for the communications box within the vicinity of the ZEB® - it should be above the height of the unit to not impede wireless signals
- Check for good WiFi strength in the area the communication box is to be mounted. If in an enclosed space check the WiFi strength with the enclosure door closed
- Check and prepare cable routing for the building thermostat call-for-heat, or connection to wireless thermostat receiver
- Check and prepare cable routing for the building wiring centre and/or external pump power supply

4.3. Water System

Water System Requirements

 CAUTION	<p>Pressurised System</p> <p>Minor or moderate personal injury</p> <ul style="list-style-type: none"> - The pressure relief valve is a safety device and if activated may discharge boiling water or steam. Take care when positioning the outlet pipe so it discharges to a safe place such that it does not pose a hazard
---	---

- All installations should comply with relevant local regulations, for example Building Regulations Part G and The Water Supply (Water Fittings) Regulations
- A pressure relief valve **MUST** be installed in the primary water system external to the ZEB®
- Isolation valves are recommended to be fitted to the flow and return pipework close to the ZEB® - however **DO NOT FIT ISOLATION BETWEEN THE ZEB® AND THE PRESSURE RELIEF VALVE**. The values should be full bore to prevent a loss in flow rate, gate valves recommended

- A magnetic filter **MUST** be installed in the return pipework to the ZEB[®] to prevent debris from fouling the ZEB's heat exchanger
- An automatic bypass valve **MUST** be installed between flow and return pipework where there are actuated radiator valves and no open circuit - to ensure minimum flow rate through the ZEB. This must be adjusted to suit the pump size and setting to provide the minimum flow rate of 3.5 l/min (210 l/hr). Typically this will need adjustment from default settings
- For sealed systems an expansion vessel must be fitted in the primary water system, ensure that the vessel is sized in accordance with the system volume
- In a sealed system the primary water system must be filled using a WRAS approved filling loop or similarly approved device
- It is recommended that a drain cock is installed at the lowest part of the system and air vents at all high points in the system. A deaerator may additionally be installed

Flushing and Filling the System

	<p>TAKE NOTICE</p> <p>Debris from the system can damage the ZEB[®] and reduce system efficiency. Failure to comply with the guidelines for water treatment may require replacement of components at the expense of the owner</p>
---	--

	<p>TAKE NOTICE</p> <p>The addition of sealing agents to the primary water system is not recommended. It can adversely affect performance of the ZEB[®]</p>
---	--

The ZEB must only be installed on heating systems which comply with current standards for water quality e.g. BS 7593:2019. This may require the system to be flushed, but it is the responsibility of the installer to determine what treatment (if any) is necessary for a given installation.

Ensure the system pipework is in good working condition before attempting to flush the system. Where possible keep the existing boiler and circulating pump in place when flushing the system.

Recommended Flushing procedure for the system:

- Fill the system with cold water and check for leaks
- Open all drain cocks and drain the system
- Close drain cocks and add a suitable flushing agent at the correct strength for the system conditions and materials in accordance with the flushing agent instructions
- Circulate the flushing agent before the existing boiler is fired up
- Run the boiler/system at normal operating temperature as directed by the manufacturer of the flushing agent
- Drain and thoroughly flush the system to remove the flushing agent and debris
- It may be necessary to use a power flushing machine in some circumstances
- Close the drain cocks and refill with water to BS 7593:2019 utilising suitable water treatment methods to prevent corrosion and fouling of heat exchanger
- Vent any air from the boiler and system

4.4. Location and Space Requirements

The ZEB[®] utilises a highly efficient insulation system to minimise heat losses. Nonetheless, it is recommended that the ZEB is installed within the heating envelope of the home for optimal performance.

Floor Loading

The ZEB[®] is intended to be installed on a level floor. The unit has a base plate to spread the load. The floor loading of the appliance is 1300 kg/m².

- Install the product on a hard, solid and level surface
- Ensure that the substrate is suitable for the floor loading

Clearances

 <p>CAUTION</p>	<p>Hot Surface Minor or moderate personal injury - Clearances are important. tepeo is not responsible for damage to personnel or property as a result of failing to comply with the clearances outlined</p>
---	--

The ZEB[®] uses high-efficiency insulation, however some heat will radiate during use. In order to avoid heat accumulation and excessive panel temperatures, the clearances outlined below must be allowed for and adhered to.

- Standard clearances around the ZEB[®] are given in **Figure 5**
- Where the ZEB[®] is surrounded by non-combustible materials, the clearance distances to the sides and front of the unit can be reduced to 10mm
- The rear of the ZEB[®] may be placed 10mm off a non-combustible wall
- The ZEB[®] requires withdrawal space to the front for access to serviceable components (as per the [Technical Specifications](#))
- Do not place items on top of the ZEB[®]

Installation in Enclosed Spaces

Where the ZEB[®] is to be installed in an enclosed space, the clearances specified above must be adhered to. Additionally, ventilation grilles must be provided at least 225mm x 150mm top and bottom of the enclosed space to provide continuous ventilation.

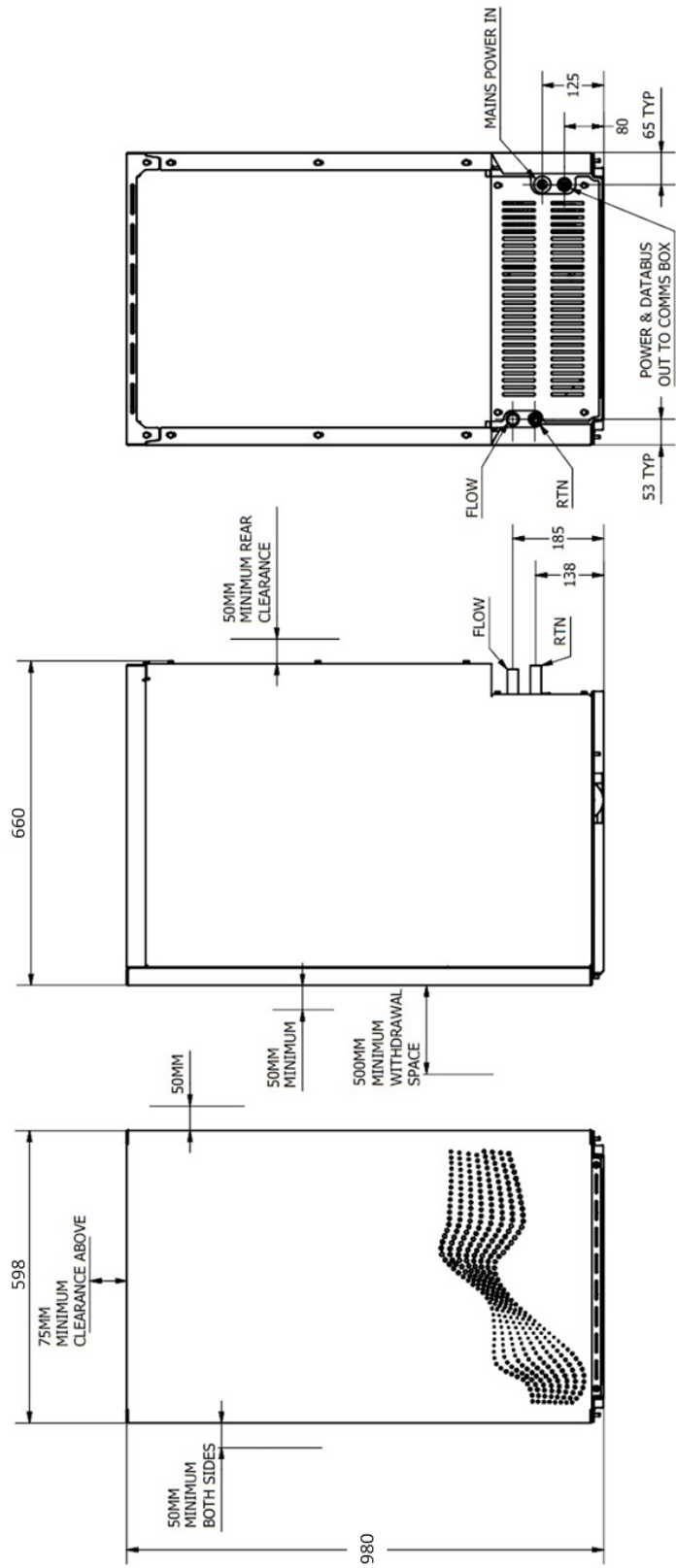



Figure 5: Standard clearance distances required around the ZEB®

5. Installation

5.1. Preparation

 CAUTION	<p>Crushing of Hands/Feet</p> <p>Minor or moderate personal injury</p> <ul style="list-style-type: none"> - Avoid placing hands or feet underneath the ZEB® when deploying castors, installing the jockey wheel or manoeuvring the ZEB®.
---	--

	<p>TAKE NOTICE</p> <p>Observe caution when using the castors and jockey wheel assembly to maneuver the ZEB®. The ZEB® is a heavy appliance and using the castors and jockey wheel will cause point loading, potentially causing damage to the floor.</p>
---	---

- Check suitability of the proposed installation location for floor loading, clearances, cabling and pipework
- Extend copper pipework from rear of the ZEB® to the left/right side or top of the unit as appropriate for the installation
- Maneuver the ZEB® where necessary using appropriate lifting equipment
- Retractable castors can be deployed for final positioning of the ZEB®. See **Figure 6**
 - Rotate each M10 bolt clockwise to deploy each castor (17mm socket and 500mm extension bar required). **Take special care not to damage or disturb the electronics when deploying the castors**
 - The castors should be raised and lowered evenly in incremental steps until both are fully deployed
 - The supplied front jockey wheel assembly (Stored in the roof of the base) should be fitted to the front of the ZEB® base once the retractable castors have been deployed and retained with the [included] flanged nuts so the jockey wheel cannot be displaced by irregularities in the floor/surface
- Ensure the front jockey wheel assembly is removed, clipped back into the base roof and the castors are returned to their retracted position once the ZEB® is sited

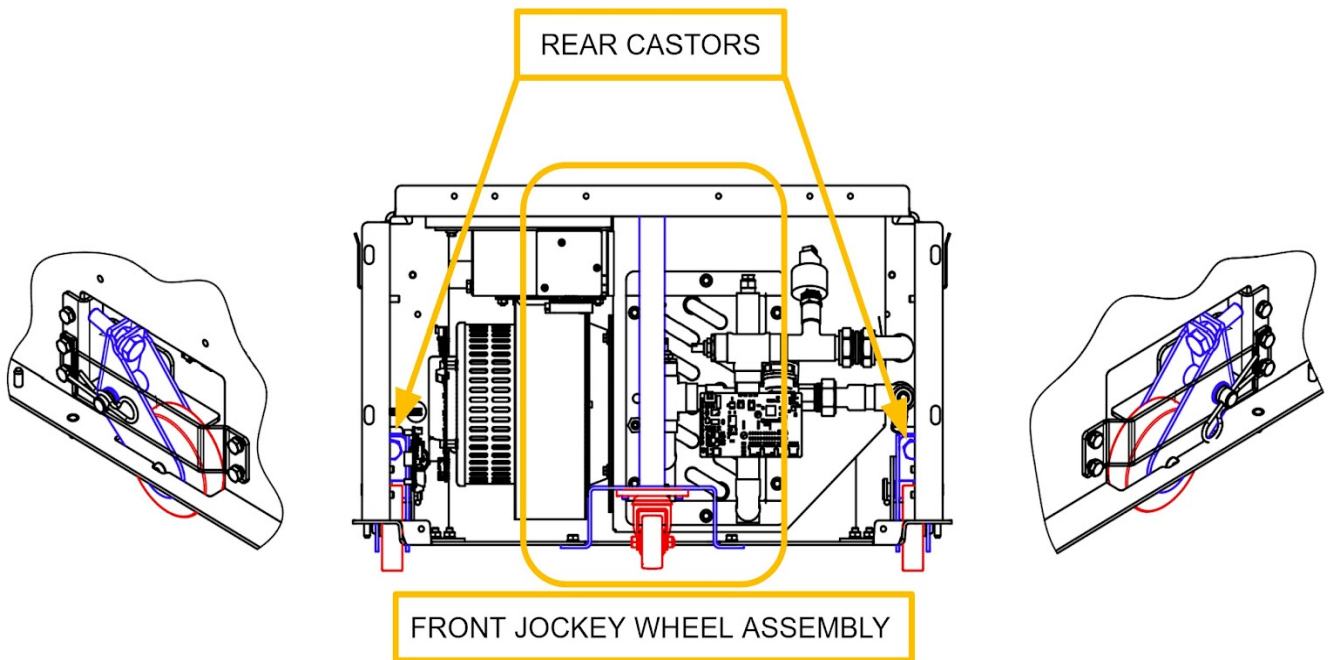



Figure 6: Castor deployment and retraction mechanism

5.2. Electrical and Wiring Installation

 DANGER	<p>Electric Shock</p> <p>Death or serious personal injury</p> <ul style="list-style-type: none"> - Switch off the power supply before starting any work - Isolate the ZEB at the local double pole switch and at the consumer unit - Follow safe isolation procedures - Use voltage indicator and proving unit to verify isolation
--	---

- Check that all pre-installation [electrical system requirements](#) are met (see section 4.1)
- Terminate the supplied ZEB® flying lead (H07 3-core 10mm²) at the double pole isolator switch for the unit
- The flying lead may be extended where necessary, if done so in accordance with applicable regulations and by a qualified electrician
- All pipe work must be earthed

- Once the electrical works have been completed, an electrical safety check should be carried out e.g. short circuits, resistance to earth, earth continuity and polarity checks

5.3. Communications Box Wiring

 DANGER	<p>Electric Shock Death or serious personal injury</p> <ul style="list-style-type: none"> - Switch off the power supply before starting any work - Isolate the ZEB at the local double pole switch and at the consumer unit - Follow safe isolation procedures - Use voltage indicator and proving unit to verify isolation
--	---

 DANGER	<p>Electric Shock Death or serious personal injury</p> <ul style="list-style-type: none"> - Check comms box in case of dual power source - e.g. from wiring centre with dedicated power supply
---	--

- Check that all pre-installation [mounting and wiring requirements](#) are met (see Section 4)
- Mount the communications box in the vicinity of the ZEB® using the 2m flying lead provided
 - Use the mounting holes on the backplate of the communications box to securely mount it to the wall, as shown in **Figure 7. Note; all three fixing locations on the back plate must be used.**
 - Where required use wall plugs
 - To refit the comms box after making connections, clip over the backplate, press firmly into place (without trapping any cables)
 - The pre-applied loctite securing screw **MUST** be re-inserted

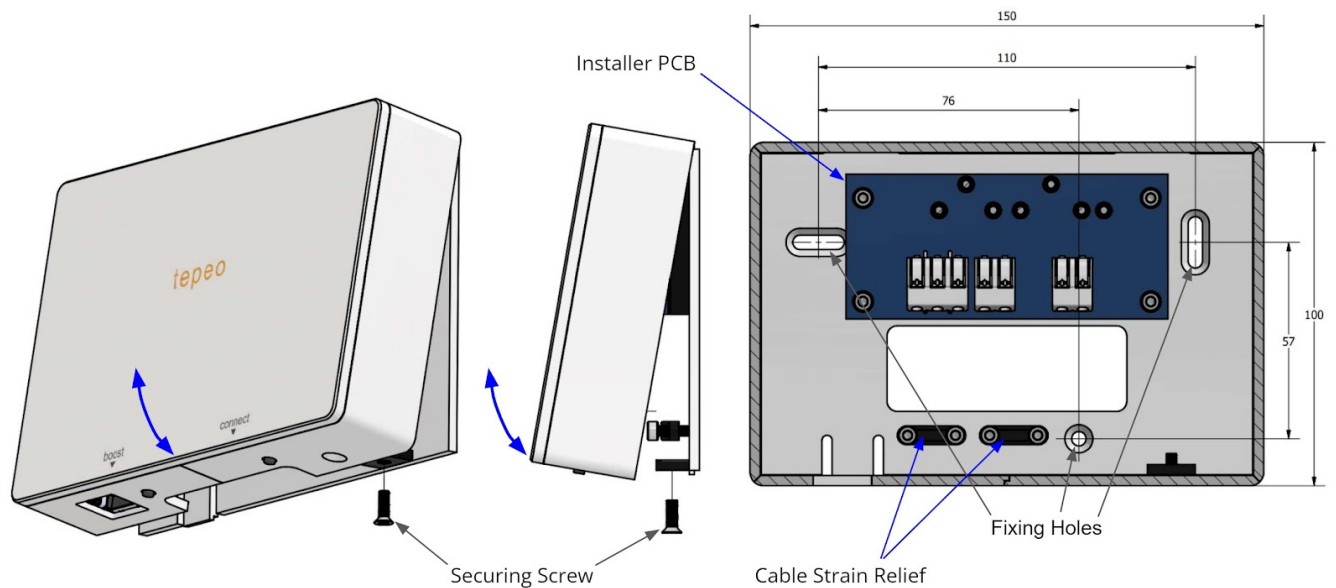

Figure 7: Comms Box outer casing install and removal

- The communications box wiring is detailed in **Figure 8**:
 - Wiring Centre power supply (230VAC - Live, Earth and Neutral)
 - External Pump (230VAC - Pump Live output)
 - Thermostat (230VAC - Switched Live input); or
 - Thermostat (volt-free)
- Check WiFi signal strength is good in the intended install location
- Where an existing wiring centre is being used, the power supply cable **MUST** be made available from the communications box to the wiring centre
 - NB requirement for a 3A unswitched fused spur in the power supply between the comms box and the existing wiring centre
- The Comms Box uses spring loaded wiring terminals. Use a small screwdriver to gently depress the tab on each terminal whilst inserting the wires, releasing to achieve connection
- Cables entering the comms box **MUST** use the provided strain relief

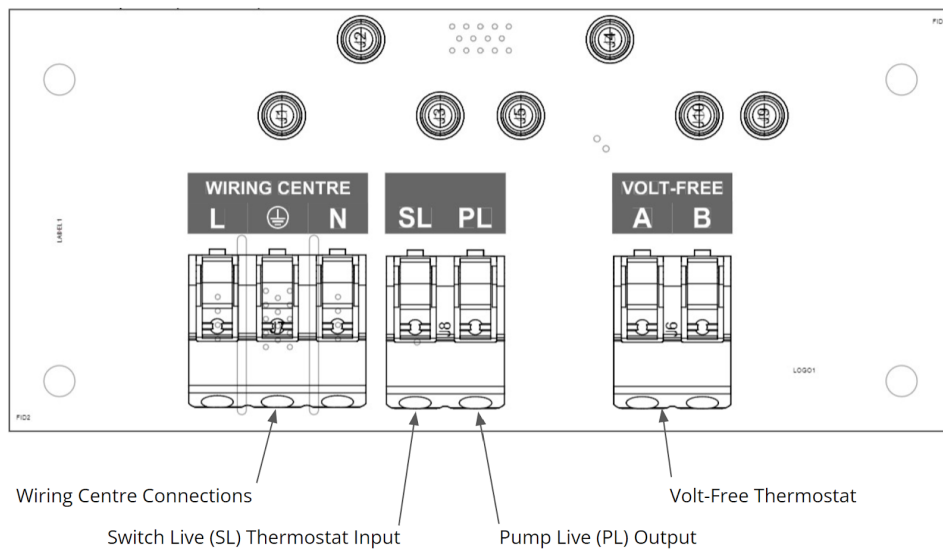

Figure 8: Comms Box wiring terminals

5.4. Plumbing Installation

- Check that all pre-installation [water system requirements](#) are met (see section 4.3)
- Connect the primary system pipework to the ZEB® using 22mm compression, press or solder type fittings
- Ensure flow and return directions are correct (**Figure 1**)
- Take care and necessary precautions when soldering to avoid heat damage to the exterior panels
- Use water soluble flux for making soldered joints and ensure any flux residue is removed following installation
- Where practical, and if possible, we recommend that all pipe-work is insulated, in particular the primary exposed pipe-work within a boiler cupboard and unheated voids. This is to reduce heat accumulation in the enclosed space and increase system efficiency

6. Commissioning

Before commissioning the ZEB® ensure that the previous sections have been fully reviewed. Pay particular attention to the electrical supply and water supply requirements.

Power On

You are now ready to power on the ZEB®.

- Switch the external double pole isolator to the ON position
- Check the 'Power' LED on the Comms box is illuminated

Plumbing Connection and System Bleeding

Any isolation valves between the ZEB® and the water heating system can now be opened. The water system may require bleeding at this point to remove air from the ZEB® pipework.



TAKE NOTICE

Before beginning commissioning please ensure that the system is filled, bled and the ZEB® has been on charge for at least 60 mins (2x 30 minute boosts, initiated via the boost button on the communications box).

This is **essential** to enable the commissioning steps and performance verification checks to be completed.

6.1. Installer Application

Before turning on the ZEB®, download the tepeoPRO installer app from the Apple appstore or Google Play store.

The Installer App will walk the installer through the commissioning checks described below to confirm the installer has completed the installation successfully, and that the ZEB® is operational.

The installer application is NOT a substitute for following instructions as detailed in this installation manual.

To register a ZEB® on the installer app:

- Download, register and log into the tepeoPRO app. You will also need to enable bluetooth and location on your device
- From the main “Dashboard page”, select “Install a ZEB”
- Tap “Scan for ZEBs” and the app will start searching for nearby ZEBs
- Press the “connect” button on the ZEB comms box (see section 7) for 1 second. This will put the ZEB® into Bluetooth discovery mode, and the LED will start flashing
- Once the app finds the ZEB, select the ZEB under “Discovered Devices” to start the commissioning checks
- The app will guide you through the key steps in the commissioning process (detailed below)

6.2. Commissioning Process

Core Charging

A minimum State of Charge is required for the ZEB® to start discharging heat. Therefore the ZEB® may require a short period of charging as part of the commissioning process if it hasn't already been manually boost-charged.

- Using the Installer App, set the ZEB® to charge
- Check that the power consumption of the ZEB® is approximately 9kW
- Check that the white 'Charging' LED is on

Call-For-Heat Functionality

To test the functionality of the ZEB® in response to a call for heat:

- Manipulate the room/tank thermostats and/or programmers to provide a call for either/both central heating and hot water
- Leave the call-for-heat engaged until all air is removed from the water system
- The installer App will prompt for return of the thermostats and/or programmers to the end user's settings later in the commissioning checks
- Repeat for Stored Hot water if there is an indirect hot water cylinder in the system

Note that the ZEB® will not deliver heat to the water circuit until the core reaches a minimum State of Charge of 2 kWh. See ‘Core Charging’ below.

Water Sensor Verification

Using the Installer App check that the water pump is active, and that the water pressure and flow rate are showing expected values, depending on whether the system is open vented or sealed.

Water pressure should be above the minimum pressure required. **0.5 - 2.0 bar** is typical depending on vented vs unvented & system design.

The pump power setting can be adjusted to give a flow rate typically in the range of **600 - 800 l/h** for optimal performance of the ZEB® - subject to target dT between flow and return temperatures and the recommendation of the qualified installer.

Discharging

With the minimum state of charge achieved and the call-for-heat still engaged:

- Check that the white 'Discharging' LED is on
- The internal air discharge fan will now be operating
- Use the Installer App to check that the internal air temperature onto the heat exchanger (HX inlet temp) is >20°C above ambient, and the water temperature is starting to rise
- Outcome: fan speed reported should be (>40 RPS), air temperatures should be >150°C, water power >3000 Watts (State of Charge and flow temperature dependant)

Reset

- Adjust the thermostats to stop the call for heat. Confirm that the ZEB power supply is less than 150 Watts

Pressure bypass

- Use the Installer App to verify/adjust the automatic bypass valve to achieve the minimum required flow of **210 l/h** when pump overrun is active

Completion

- Return the room/tank thermostats and/or programmers to the end user's setting
- Using the Installer App, confirm that the ZEB® detects the absence of the call-for-heat, and that the internal air fan and external water pump stop

- Verify this for all heating and hot water zones. Test them separately
- Review commissioning results
- Confirm commissioning completed within nominal parameters

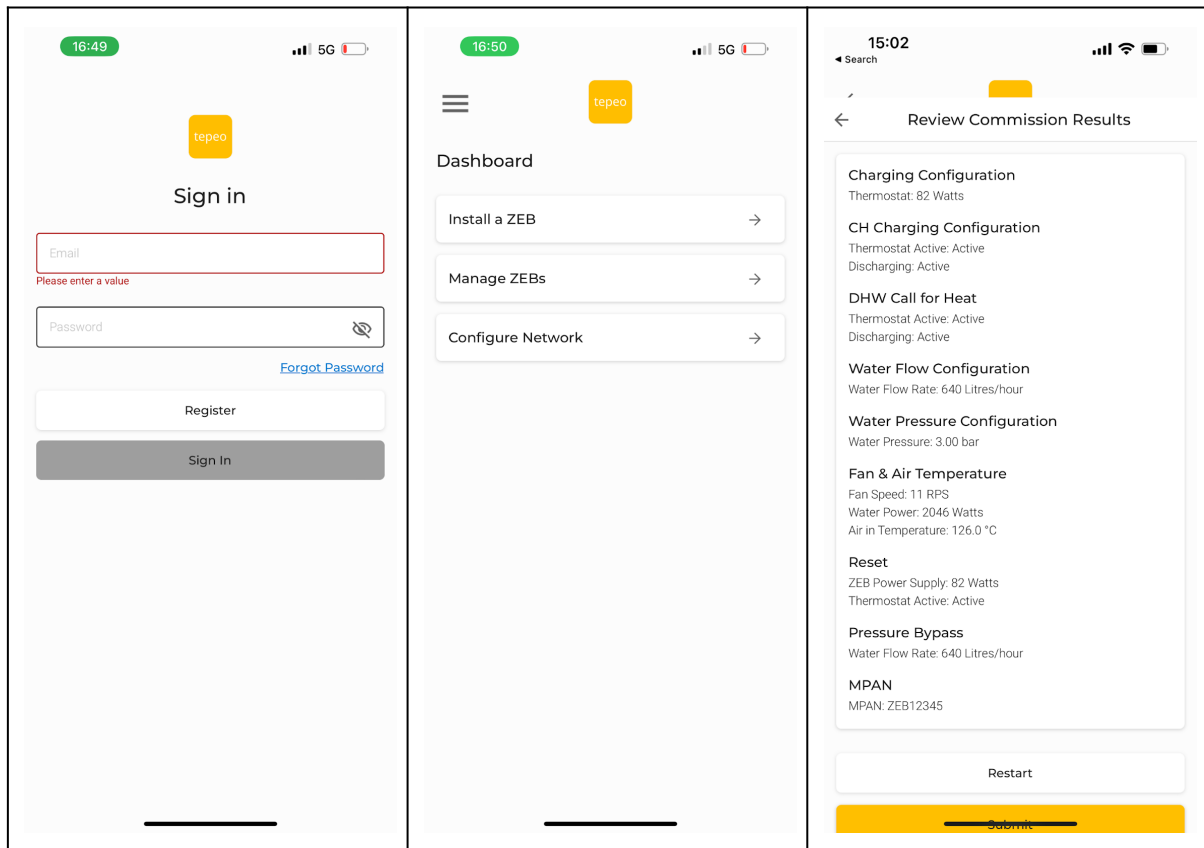

6.3. End User Handover

Finally, the Installer App will request an email address for the end user, to confirm to the end user that the commissioning checks have been completed, and inviting the end user to register a tepeo User Account.

Please help the customer to get their ZEB set up on the tepeo customer app by:

- pairing to ZEB via bluetooth (see section 7)
- getting ZEB online with their Wi-Fi credentials
- setting tariff and other preferences in settings
- set up thermostat/heating controls and schedule/setpoints
- set ZEB water flow temperature setpoint

Creating a tepeo User Account and connecting the ZEB to it will automatically register the guarantee. If the customer wants to complete account setup at a later date, they will need to register the guarantee by filling in a form on www.tepeo.com/guarantee/register. This needs to be done within the timescale specified in their guarantee terms, which can be found on www.tepeo.com/terms

7. Operation

Always read the safety instructions in Section 2 of the manual before operating the ZEB®.

7.1. Switch On/Off



TAKE NOTICE

Before switching off at the isolator it is recommended that the ZEB is in idle mode, i.e. call for heat is off and the ZEB is not charging/discharging.

Power is supplied to the ZEB® via the local 2-pole Isolator Switch. The ZEB® will remain in operation whilst it is connected to the mains. To turn off the ZEB®, disconnect power by switching the Isolator Switch to the OFF position.

7.2. Comms Box Buttons, LED Indicators and Status

The LED indicator lights are on the front of the Comms box, and show the state of the ZEB® as detailed in **Figure 9**. Also shown are the locations of the two comms box buttons.

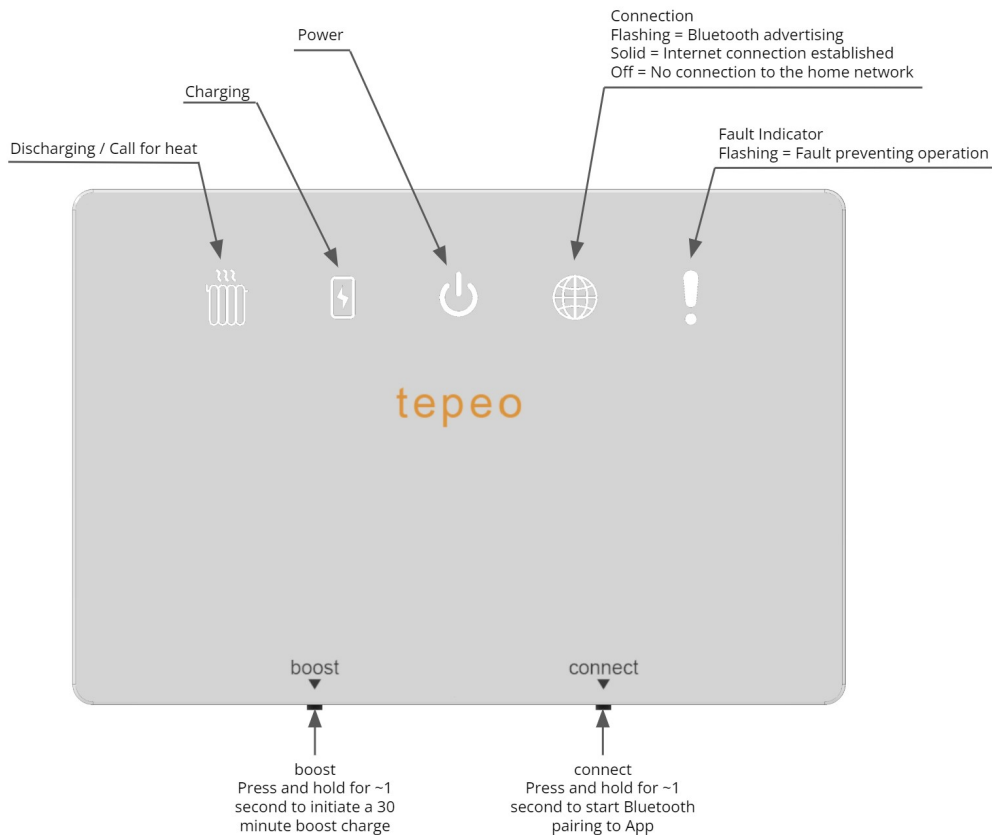

Figure 9: Indication lights location on Comms [Communications] box

7.3. User App

Download the ZEB® User App from the App Store or Google Play, and register a User Account.

A User Account will enable the end user to monitor the performance of the ZEB®, and to change operational settings such as the WiFi network, Tariff and Cost/Carbon preference.

To register a ZEB® on the user app:

- Log in via the app
- Press the CONNECT button on the Comms box. This will put the ZEB® into bluetooth discovery mode, and the white connection LED will start to flash

Use the 'Link ZEB®' in the menu and Scan for the ZEB®

Select a ZEB® from the list to link the ZEB® to the User Account

The User can now view the Summary page, and the Status of the ZEB

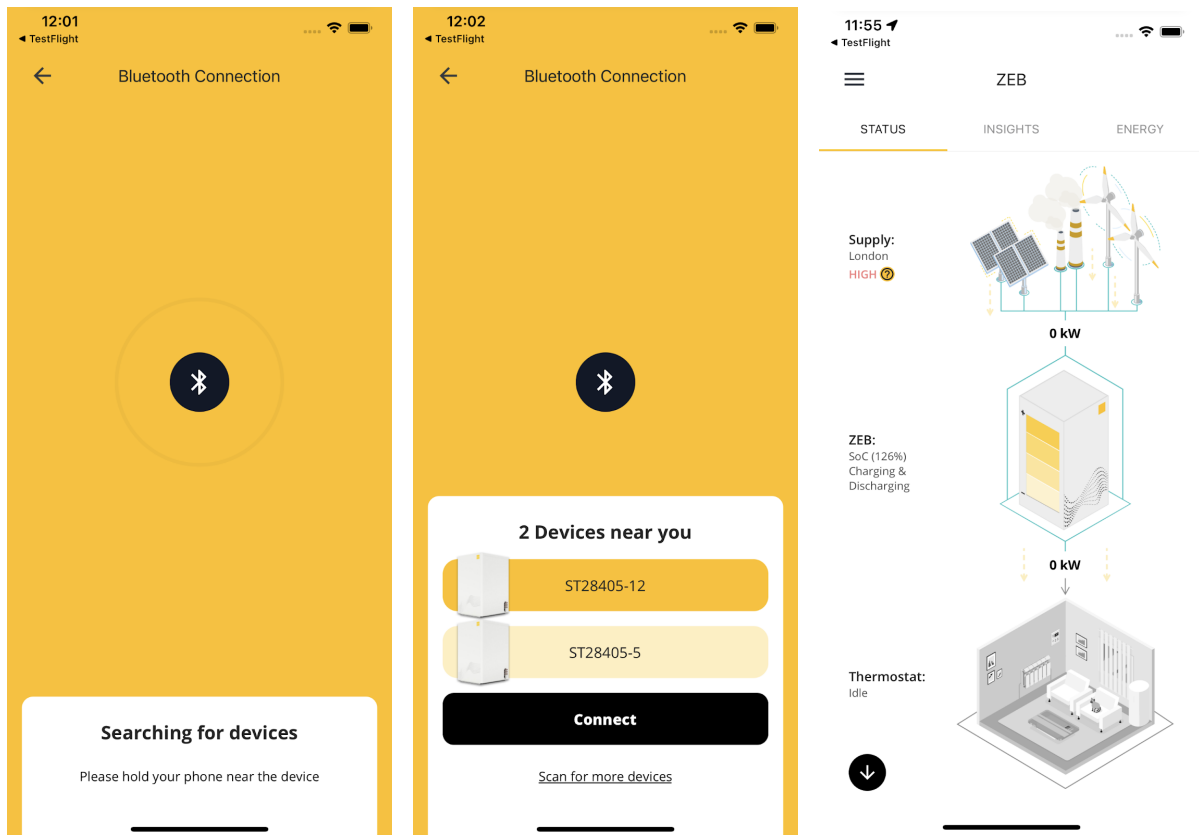

Figure 10: ZEB® User App

- Use the Account page in the menu to change any operational settings of the ZEB® (**Figure 11** - refer to user guide for full details) including
 - ZEB® Display Name
 - Location
 - Tariff
 - Energy consumption preference (low cost / low carbon intensity)
 - ZEB® water flow temperature setpoint

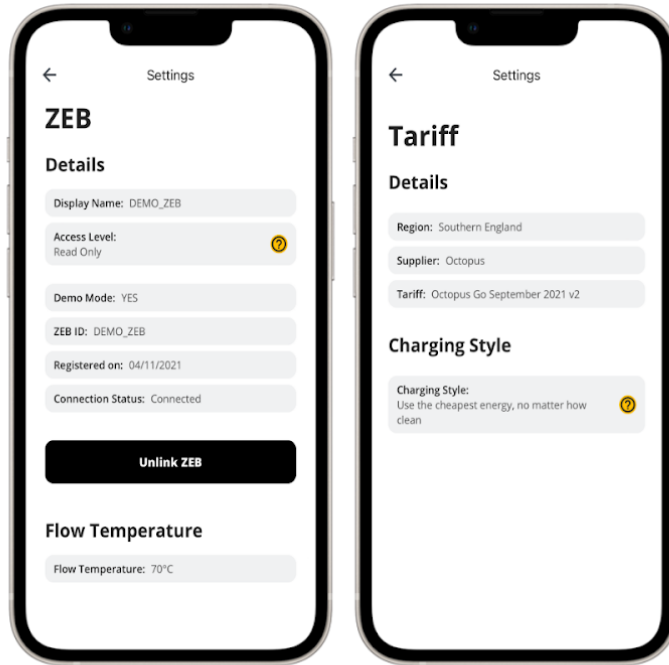



Figure 11: User App Account Settings

8. Maintenance

 DANGER	<p>Electric Shock</p> <p>Death or serious personal injury</p> <ul style="list-style-type: none"> - Switch OFF the power supply before starting any work - Isolate the ZEB at the local double pole switch and at the consumer unit - Follow safe isolation procedures - Use voltage indicator and proving unit to verify isolation
--	---

Any servicing or maintenance must be carried out by tepeo or a competent and qualified engineer who is registered with tepeo. Service details must be recorded and available for inspection upon request.

Please refer to the tepeo Service and Maintenance Manual for further details.

- Maintenance should be carried out by qualified personnel only
- Ensure the unit is electrically isolated before carrying out any maintenance, repair or removal work
- Ensure appropriate PPE is used during maintenance, including eye protection, gloves, overalls and (e.g. FFP2) respirator where appropriate
- If the supply cable is damaged, it must be replaced by the manufacturer, its service agent or similarly qualified persons

8.1. Support - Care Plans

Some maintenance is required to keep the ZEB[®] working at its best.

Customers can arrange an annual ZEB[®] Health Check or sign up to a care plan to maintain their product guarantee. Details can be found at www.tepeo.com

8.2. Front panel removal

- Use a 5mm allen key to remove the two screws at the bottom of the front panel

- The front cover can now be lifted off and removed, in an up-and-away movement as shown in **Figure 12**
- For re-installation of the panel reverse the above steps, and ensure the two securing bolts to hold the front panel in place (with star washers) are securely fastened

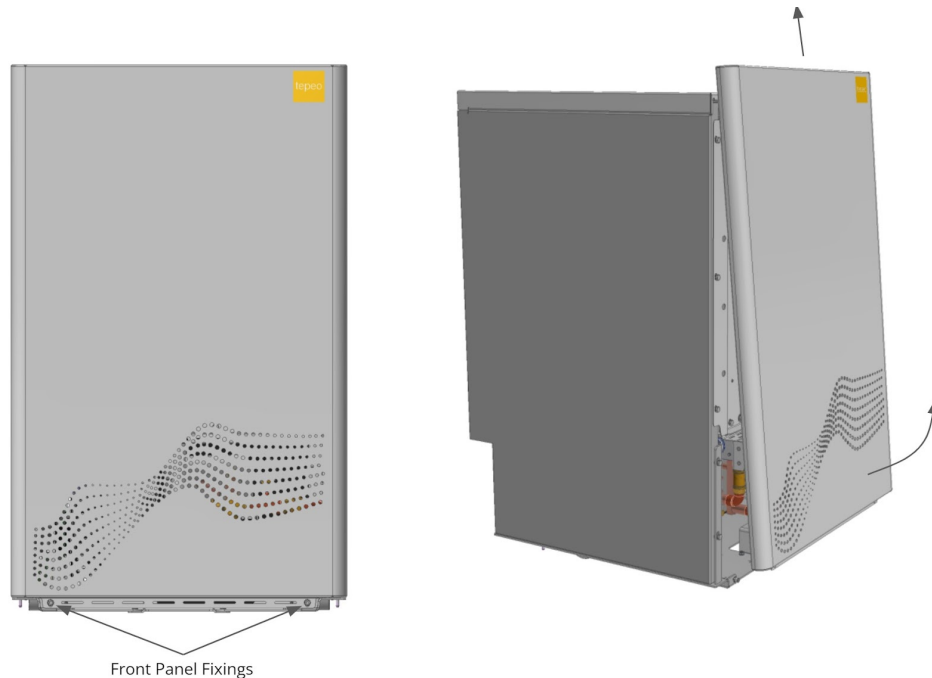



Figure 12: Front dress panel removal

8.3. Cleaning

- The product does not require any regular cleaning
- Should the product exterior need cleaning, it can be wiped down with a damp cloth and a mild detergent. In no circumstances should the ZEB become wet or immersed

9. Recycling and Disposal

	<p>TAKE NOTICE Safe Disposal</p> <p>- When this product reaches its end of life, it must be disposed of separately from household waste. Send to an authorised centre for disposal and recycling, as designated by the local waste disposal authorities.</p>
---	--

- Discard or recycle packaging according to local disposal or recycling rules
- The ZEB® should not be mixed with general household waste at the end of its life
- For proper treatment, recovery and recycling, please take this product to a collection point as designated by local waste disposal authorities at the end of its life
- Disposing of this product correctly will help save valuable resources and prevent any potential negative effects on human health and the environment, which could otherwise arise from inappropriate waste handling
- Please contact your local authority for further details of your nearest designated collection point. Penalties may be applicable for incorrect disposal of this waste, in accordance with national legislation

10. Appendices

10.1. Example Comms Box Wiring Diagrams

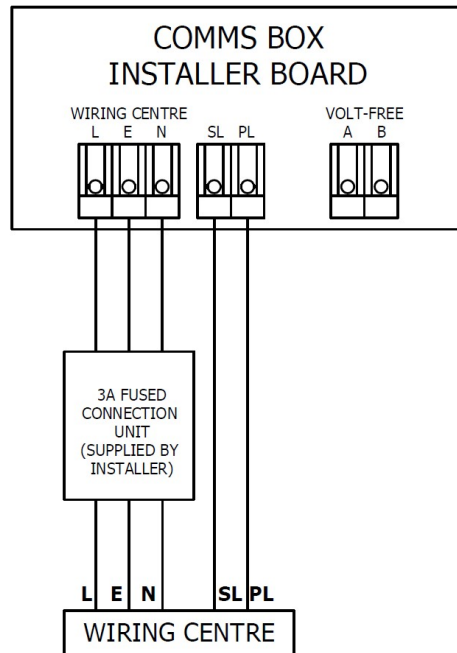

Figure 13: 230V switched live heating controls (S Plan or similar)

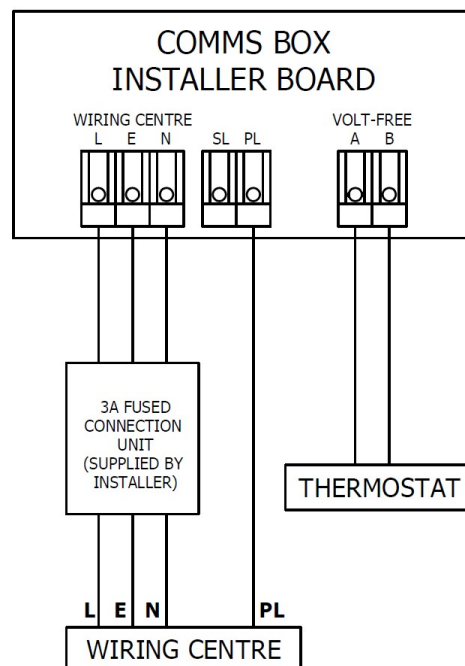

Figure 14: Volt free/low voltage/potential free thermostat (space heating only systems).



heat your home, not the planet